

TABLAS DE CASQUILLO CÓNICO

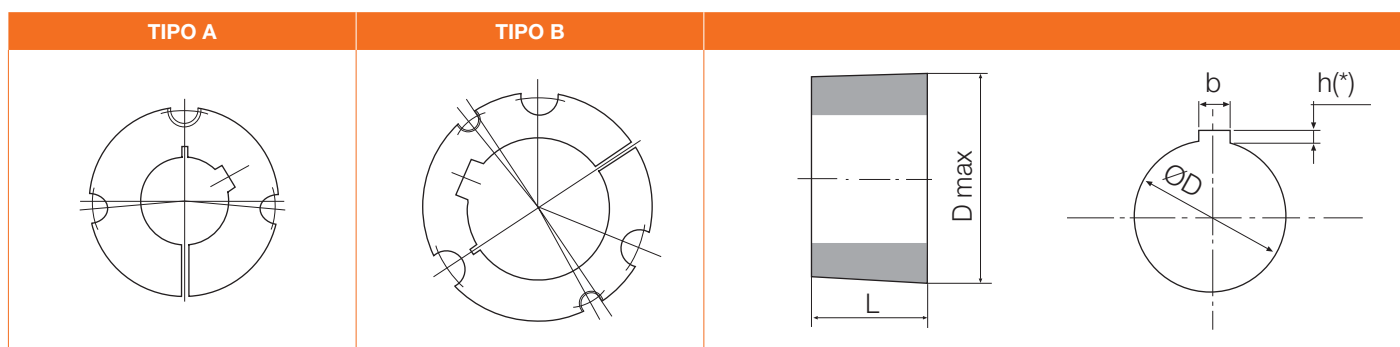

TIPO		1008 A	1108 A	1210 A	1215 A	1310 A	1610 A	1615 A	2012 A	2517 A	2525 A	3020 A	3030 A	3525 B	3535 B	4040 B	4545 B	5050 B
Peso con Ø D mín.	Kg	0,12	0,16	0,28	0,39	0,32	0,42	0,61	0,75	1,10	2,25	2,61	3,80	3,90	5,25	7,80	12,80	15,30
D máx.	mm	35,0	38,0	47,5	47,5	50,5	57,0	57,0	70,0	85,5	85,5	108,0	108,0	127,0	127,0	146,0	162,0	177,5
L	mm	22,3	22,3	25,4	38,1	25,4	25,4	38,1	31,8	44,5	63,5	50,8	76,2	63,5	88,9	101,8	114,3	127,0
Tornillos de hexágono interior (Allen)		1/4" x 1/2"	1/4" x 1/2"	3/8" x 5/8"	3/8" x 5/8"	3/8" x 5/8"	3/8" x 5/8"	3/8" x 5/8"	7/16" x 7/8"	1/2" x 1"	1/2" x 1"	5/8" x 1 1/4"	5/8" x 1 1/4"	1/2" x 1 1/2"	1/2" x 1 1/2"	5/8" x 1 3/4"	3/4" x 2"	7/8" x 2 1/4"
Tamaño de la llave hexagonal (Allen)	Nr	3,0	3,0	5,0	5,0	5,0	5,0	5,0	5,0	6,0	6,0	8,0	8,0	10,0	10,0	12,0	14,0	14,0
Par de apriete	Nm.	5,7	5,7	20	20	20	20	20	31	49	49	92	92	115	115	172	195	275

Ø D mm	b mm	h mm	*	1008	1108	1210	1215	1310	1610	1615	2012	2517	2525	3020	3030	3525	3535	4040	4545	5050	
9	3	1,4																			
10	3	1,4																			
11	4	1,8																			
12	4	1,8																			
14	5	2,3																			
15	5	2,3																			
16	5	2,3																			
18	6	2,8																			
19	6	2,8																			
20	6	2,8																			
22	6	2,8																			
24	8	3,3	2	*																	
25	8	3,3	1,3	*																	
28	8	3,3	2		*																
30	8	3,3																			
32	10	3,3																			
35	10	3,3																			
38	10	3,3																			
40	12	3,3																			
42	12	3,3	2,2						*	*											
45	14	3,8																			
48	14	3,8																			
50	14	3,8																			
55	16	4,3																			
60	18	4,4																			
65	18	4,4																			
70	20	4,9																			
75	20	4,9																			
80	22	5,4																			
85	22	5,4																			
90	25	5,4																			
95	25	5,4																			
100	28	6,4																			
105	28	6,4																			
110	28	6,4																			
115	32	7,4																			
120	32	7,4																			
125	32	7,4																			

Chaveteros según DIN 6885 hoja 1

*Chaveteros según DIN 6885 hoja 3

Por necesidades de fabricación, las especificaciones de este catálogo pueden ser variadas sin previo aviso.