

1.9

Fresa frontal, FORMAT GT, aluminio

Características: Con corte al centro, adecuada para taladrar. Superficie pulida.

Aplicación: Indicada para el mecanizado de HPC.

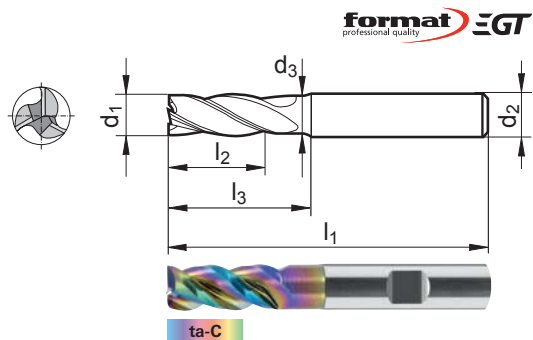
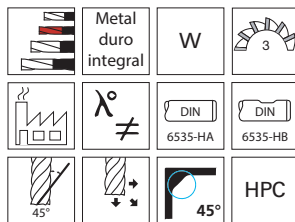

Aplicación	ACERO			INOX			FUNDICIÓN		ALEACIONES ESPECIALES	METALES NO FÉRRICOS				ACERO TEMPLADO			Ref.
	< 700 N/mm ²	< 1000 N/mm ²	< 1400 N/mm ²	Ferrit./ martens.	Aus-tenítico	Duplex	GG/ GTS	GGG	Titanio > 850 N/mm ²	Alumi- nio < 8% Si	Alumi- nio > 8% Si	Aleaciones de cobre y cinc	GFRP/CFRP/ Duropl.	< 55 HRC	< 60 HRC	> 60 HRC	
V _c [m/min]	-	-	-	-	-	-	-	-	-	730	650	-	260	-	-	-	1937

Ø d ₁ mm	Destalonado lateral del cuello l ₃ mm	Ø de cuello d ₃ mm	Longitud de filos l ₂ mm	Longitud total l ₁ mm	Ø vástago d ₂ = h6 mm	Bisel angular 45° mm	Tipo de vástago	ALUMINIO < 8% Si		Ref.
								f _t mm	1937 ta-C €	
3	2.9	2.9	12	57	6	0.1	HA	0.01	61,58	...0300
3	2.9	2.9	12	57	6	0.1	HB	0.01	61,58	...0301
4	3.9	3.9	12	57	6	0.1	HA	0.02	61,58	...0400
4	3.9	3.9	12	57	6	0.1	HB	0.02	61,58	...0401
5	4.9	4.9	15	57	6	0.1	HA	0.025	61,58	...0500
5	4.9	4.9	15	57	6	0.1	HB	0.025	61,58	...0501
6	5.8	5.8	15	57	6	0.1	HA	0.03	61,58	...0600
6	5.8	5.8	15	57	6	0.1	HB	0.03	61,58	...0601
8	7.8	7.8	22	64	8	0.1	HA	0.042	68,54	...0800
8	7.8	7.8	22	64	8	0.1	HB	0.042	68,54	...0801
10	9.7	9.7	25	73	10	0.2	HA	0.055	106,23	...1000
10	9.7	9.7	25	73	10	0.2	HB	0.055	106,23	...1001
12	11.7	11.7	28	84	12	0.2	HA	0.075	152,60	...1200
12	11.7	11.7	28	84	12	0.2	HB	0.075	152,60	...1201
16	15.7	15.7	35	93	16	0.2	HB	0.1	255,46	...1600
20	19.5	19.5	41	104	20	0.2	HB	0.12	395,86	...2000

(W201)

Fresa frontal, FORMAT GT, aluminio

Características: Con corte al centro, adecuada para taladrar. Superficie pulida.

Aplicación: Indicada para el mecanizado de HPC.

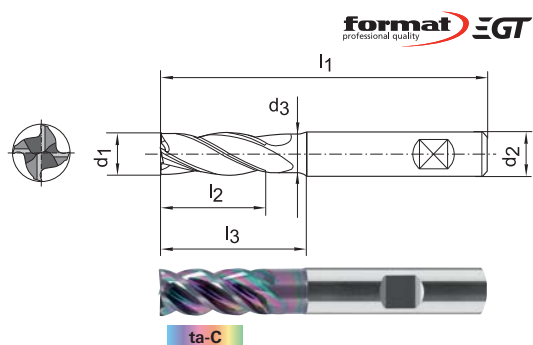
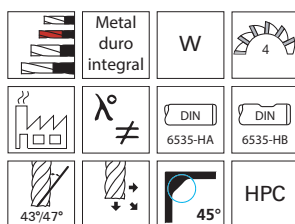

Aplicación	ACERO			INOX			FUNDICIÓN		ALEACIONES ESPECIALES	METALES NO FÉRRICOS				ACERO TEMPLADO			Ref.
	< 700 N/mm ²	< 1000 N/mm ²	< 1400 N/mm ²	Ferrit./ martens.	Aus-tenítico	Duplex	GG/ GTS	GGG	Titanio > 850 N/mm ²	Alumi- nio < 8% Si	Alumi- nio > 8% Si	Aleaciones de cobre y cinc	GFRP/CFRP/ Duropl.	< 55 HRC	< 60 HRC	> 60 HRC	
V _c [m/min]	-	-	-	-	-	-	-	-	-	520	450	-	300	-	-	-	1938

Ø d ₁ mm	Destalonado lateral del cuello l ₃ mm	Ø de cuello d ₃ mm	Longitud de filos l ₂ mm	Longitud total l ₁ mm	Ø vástago d ₂ = h6 mm	Bisel angular 45° mm	Tipo de vástago	ALUMINIO < 8% Si		Ref.
								f _t mm	1938 ta-C €	
3	10	2.9	6	57	6	0.1	HA	0.032	75,93	...0300
4	14	3.9	8	57	6	0.1	HA	0.045	75,93	...0400
5	16	4.9	10	57	6	0.1	HA	0.05	75,93	...0500

(W201)

Continúa en la página siguiente

Fresa frontal, FORMAT GT, aluminio

Continuado de la página anterior

Ø d ₁ mm	Destalonado lateral del cuello l ₃ mm	Ø de cuello d ₃ mm	Longitud de fillos l ₂ mm	Longitud total l ₁ mm	Ø vástago d ₂ = h6 mm	Bisel angular 45° mm	Tipo de vástago	format EGT		Ref.
								ALUMINIO < 8% Si f _z mm	1938 ta-C €	
6	19	5.8	12	57	6	0.2	HA	0.06	79,19	...0600
8	25	7.8	16	63	8	0.2	HA	0.08	91,02	...0800
8	25	7.8	16	63	8	0.2	HB	0.08	91,02	...0801
10	30	9.7	20	72	10	0.2	HA	0.09	156,66	...1000
10	30	9.7	20	72	10	0.2	HB	0.09	156,66	...1001
12	36	11.7	24	83	12	0.2	HA	0.1	213,14	...1200
12	36	11.7	24	83	12	0.2	HB	0.1	213,14	...1201
16	42	15.7	32	92	16	0.2	HB	0.13	399,21	...1600
20	52	19.5	40	104	20	0.2	HB	0.16	576,84	...2000

(W201)

Fresa toroidal, FORMAT GT, aluminio

Características: Con corte al centro, adecuada para taladrar. Superficie pulida.

Aplicación: Indicada para el mecanizado de HSC.

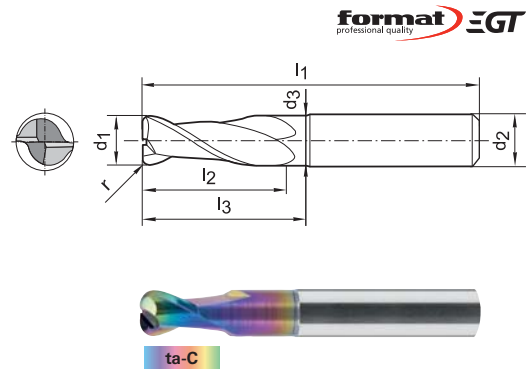
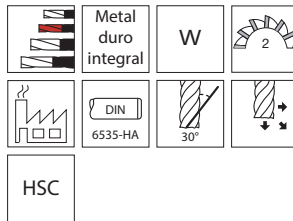

Aplicación	ACERO			INOX			FUNDICIÓN		ALEACIONES ESPECIALES	METALES NO FÉRRICOS				ACERO TEMPLADO			Ref.
	< 700 N/mm ²	< 1000 N/mm ²	< 1400 N/mm ²	Ferrit./ martens.	Aus-tenítico	Duplex	GG/GTS	GGG	Titanio > 850 N/mm ²	Alumini- nio < 8% Si	Alumi- nio > 8% Si	Aleaciones de cobre y cinc	GFRP/CFRP/ Duopl.	< 55 HRC	< 60 HRC	> 60 HRC	
V _c [m/min]	-	-	-	-	-	-	-	-	-	180	150	-	120	-	-	-	1939

Ø d ₁ mm	Radio angular r mm	Destalonado lateral del cuello l ₃ mm	Ø de cuello d ₃ mm	Longitud de fillos l ₂ mm	Longitud total l ₁ mm	Ø vástago d ₂ = h6 mm	format EGT		Ref.
							ALUMINIO < 8% Si f _z mm	1939 ta-C €	
3	0.3	14	2.9	4	50	6	0.01	68,86	...0300
4	0.3	16	3.9	5	50	6	0.017	78,96	...0400
5	0.3	18	4.9	6	54	6	0.02	85,26	...0500
6	0.3	21	5.8	7	57	6	0.03	94,38	...0600
6	1	21	5.8	7	57	6	0.03	94,38	...0601
6	2	21	5.8	7	57	6	0.03	94,38	...0602
8	0.3	27	7.8	9	63	8	0.04	126,52	...0800
8	1	27	7.8	9	63	8	0.04	126,52	...0801
8	2	27	7.8	9	63	8	0.04	126,52	...0802
10	0.3	32	9.7	11	72	10	0.05	167,48	...1000
10	1.5	32	9.7	11	72	10	0.05	167,48	...1001
10	3	32	9.7	11	72	10	0.05	167,48	...1002
12	1.5	38	11.7	13	83	12	0.07	224,96	...1200
12	4	38	11.7	13	83	12	0.07	224,96	...1201
16	2	44	15.7	17	92	16	0.09	367,06	...1600
16	5	44	15.7	17	92	16	0.09	367,06	...1601

(W201)