

1.9

Fresa toroidal, FORMAT GT, aluminio

Características: Con corte al centro, adecuada para taladrar. Superficie pulida.

Aplicación: Indicada para el mecanizado de HSC.

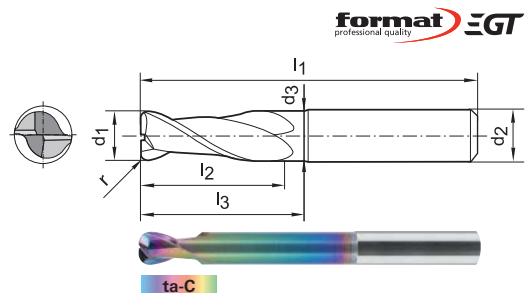
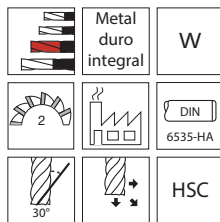

Aplicación	ACERO			INOX			FUNDICIÓN		ALEACIONES ESPECIALES	METALES NO FÉRRICOS				ACERO TEMPLADO			Ref.
	< 700 N/mm²	< 1000 N/mm²	< 1400 N/mm²	Ferrit./ martens.	Aus-tenítico	Duplex	GG/GTS	GGG	Titanio > 850 N/mm²	Alumi- nio < 8% Si	Alumi- nio > 8% Si	Aleaciones de cobre y cinc	GFRP/CFRP/ Duropl.	< 55 HRC	< 60 HRC	> 60 HRC	
V _c [m/min]	-	-	-	-	-	-	-	-	-	280	150	-	160	-	-	-	1940

Ø d ₁ mm	Radio angular r mm	Destalonado lateral del cuello l ₃ mm	Ø de cuello d ₃ mm	Longitud de filos l ₂ mm	Longitud total l ₁ mm	Ø vástago d ₂ = h6 mm	ALUMINIO < 8% Si		Ref.
							f _z mm	1940 ta-C €	
3	0.3	32	2.9	4	75	6	0.01	91,33	...0300
4	0.3	36	3.9	5	75	6	0.017	101,17	...0400
5	0.3	40	4.9	6	75	6	0.02	111,64	...0500
6	0.3	44	5.8	7	80	6	0.03	120,45	...0600
6	1	44	5.8	7	80	6	0.03	120,45	...0601
6	2	44	5.8	7	80	6	0.03	120,45	...0602
8	0.3	54	7.8	9	100	8	0.04	168,85	...0800
8	1	54	7.8	9	100	8	0.04	168,85	...0801
8	2	54	7.8	9	100	8	0.04	168,85	...0802
10	0.3	60	9.7	11	100	10	0.05	227,56	...1000
10	1.5	60	9.7	11	100	10	0.05	227,56	...1001
10	3	60	9.7	11	100	10	0.05	227,56	...1002
12	1.5	75	11.7	13	120	12	0.07	303,64	...1200
12	4	75	11.7	13	120	12	0.07	303,64	...1201
16	2	92	15.7	17	150	16	0.09	512,60	...1600
16	5	92	15.7	17	150	16	0.09	512,60	...1601

(W201)

Fresa toroidal, FORMAT GT, aluminio

Características: Con corte al centro, adecuada para taladrar. Superficie pulida.

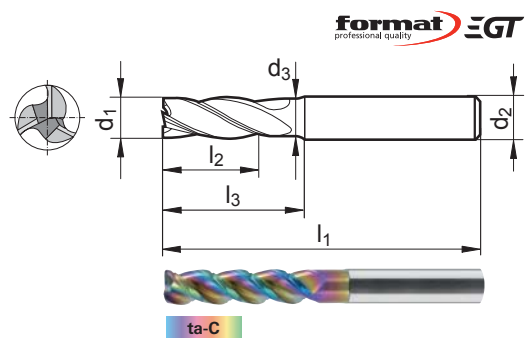
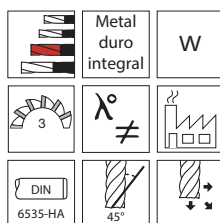

Aplicación	ACERO			INOX			FUNDICIÓN		ALEACIONES ESPECIALES	METALES NO FÉRRICOS				ACERO TEMPLADO			Ref.
	< 700 N/mm²	< 1000 N/mm²	< 1400 N/mm²	Ferrit./ martens.	Aus-tenítico	Duplex	GG/GTS	GGG	Titanio > 850 N/mm²	Alumi- nio < 8% Si	Alumi- nio > 8% Si	Aleaciones de cobre y cinc	GFRP/CFRP/ Duropl.	< 55 HRC	< 60 HRC	> 60 HRC	
V _c [m/min]	-	-	-	-	-	-	-	-	-	260	200	-	120	-	-	-	1941

Ø d ₁ mm	Radio angular r mm	Destalonado lateral del cuello l ₃ mm	Ø de cuello d ₃ mm	Longitud de filos l ₂ mm	Longitud total l ₁ mm	Ø vástago d ₂ = h6 mm	ALUMINIO < 8% Si		Ref.
							f _z mm	1941 ta-C €	
3	0.5	31	5.8	25	71	6	0.07	92,00	...0300
3	1	31	5.8	25	71	6	0.07	92,00	...0301

(W201)

Continúa en la página siguiente

Fresa toroidal, FORMAT GT, aluminio

Continuado de la página anterior

Ø d ₁ mm	Radio angular r mm	Destalonado lateral del cuello l ₃ mm	Ø de cuello d ₃ mm	Longitud de fillos l ₂ mm	Longitud total l ₁ mm	Ø vástago d ₂ = h6 mm	format Δ GT		Ref.
							ALUMINIO < 8% Si f _z mm	1941 ta-C €	
8	0.5	41	7.8	33	80	8	0.1	109,29	...0800
8	1	41	7.8	33	80	8	0.1	109,29	...0801
8	2	41	7.9	33	80	8	0.1	109,29	...0802
10	0.5	51	9.7	41	95	10	0.13	162,74	...1000
10	1	51	9.7	41	95	10	0.13	162,74	...1001
10	2	51	9.7	41	95	10	0.13	162,74	...1002
12	0.5	61	11.7	49	109	12	0.17	221,60	...1200
12	1	61	11.7	49	109	12	0.17	221,60	...1201
12	2	61	11.7	49	109	12	0.17	221,60	...1202
16	2	81	15.7	65	132	16	0.22	409,44	...1600
16	3	81	15.7	65	132	16	0.22	409,44	...1601
20	2	101	19.5	82	154	20	0.3	597,13	...2000
20	3	101	19.5	82	154	20	0.3	597,13	...2001

(W201)

Fresa esférica, FORMAT GT, aluminio

Características: Con corte al centro, adecuada para taladrar. Superficie pulida.

Aplicación: Indicada para el mecanizado de HSC.

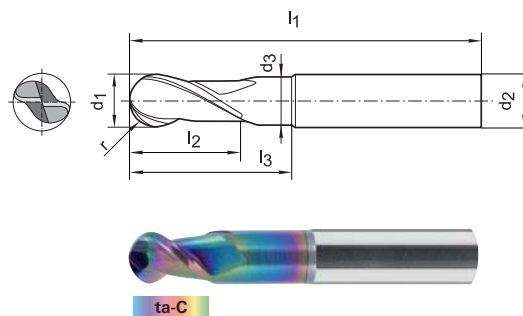
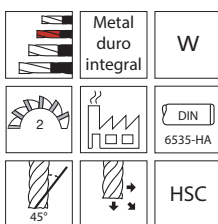

Aplicación	ACERO			INOX			FUNDICIÓN		ALEACIONES ESPECIALES	METALES NO FÉRRICOS				ACERO TEMPLADO			Ref.
	< 700 N/mm ²	< 1000 N/mm ²	< 1400 N/mm ²	Ferrit./ martens.	Aus- tenítico	Duplex	GG/ GTS	GGG	Titanio > 850 N/mm ²	Alumi- nio < 8% Si	Alumi- nio > 8% Si	Aleaciones de cobre y cinc	GFRP/CFRP/ Duropl.	< 55 HRC	< 60 HRC	> 60 HRC	
V _c [m/min]	-	-	-	-	-	-	-	-	-	600	540	-	500	-	-	-	1942

Ø d ₁ mm	Radio mm	Destalonado lateral del cuello l ₃ mm	Ø de cuello d ₃ mm	Longitud de fillos l ₂ mm	Longitud total l ₁ mm	Ø vástago d ₂ = h6 mm	format Δ GT		Ref.
							ALUMINIO < 8% Si f _z mm	1942 ta-C €	
3	1.5	16	2.9	6	50	3	0.025	66,93	...0300
4	2	17	3.9	7	54	4	0.03	78,76	...0400
5	2.5	18	4.9	8	54	5	0.05	89,28	...0500
6	3	21	5.8	10	54	6	0.06	89,28	...0600
8	4	27	7.8	12	59	8	0.07	109,29	...0800
10	5	32	9.8	13	67	10	0.085	144,78	...1000
12	6	38	11.7	16	73	12	0.1	185,18	...1200
16	8	44	15.7	20	83	16	0.15	307,88	...1600

(W201)