

Fresa acoplable planear, 45°

Ø D mm	Z	Ø d H7 mm	L mm	Ø D1 mm	a _p máx. mm	Plaquita de corte	format	
							2999	Ref.
40	3	16	40	53	6,5	SEET/SEKT 1204...	244,66	...2050
50	4	22	48	65	6,5	SEET/SEKT 1204...	271,81	...2055
63	5	22	48	78	6,5	SEET/SEKT 1204...	306,54	...2060
80	6	27	50	95	6,5	SEET/SEKT 1204...	338,26	...2065
100	6	32	50	115	6,5	SEET/SEKT 1204...	395,65	...2070
125	7	40	63	140	6,5	SEET/SEKT 1204...	484,71	...2075
160	8	40	63	173	6,5	SEET/SEKT 1204...	948,38	...2080

(W280)



format
professional quality

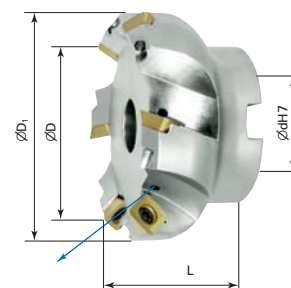

Suminis-
tro sin
plaquitas
de corte.

Pieza de recambio

Características	U.E.	format	
		2999	Ref.
Tornillo	5 Δ	8,41	...0193

(W281)

Δ Solo es posible la entrega de una unidad de embalaje completa.



Tornillo

Plaquita de corte ISO

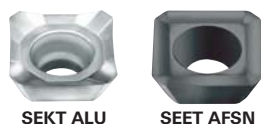

format
professional quality

Designación ISO	Tipo de material de corte	Velocidad de corte Avance Profundidad de corte	P Acero	M Inoxidable	K Fundición	N Aluminio	S Superalc.	H Templado	U.E.	format	
										2999	Ref.
SEKT 1204	Aluminio 	v _c m/min f _z mm a _p mm	-	-	-	250-1000 0,12-0,4 0,2-7	-	-	10 Δ	17,91	...5176
SEET 1204AFSN	UNI 	v _c m/min f _z mm a _p mm	255-370 0,20-0,40 1,0-6,5	150-220 0,20-0,30 1,0-4,9	-	-	50-110 0,20-0,24 1,0-3,9	-	10 Δ	24,70	...5170
SEET 1204AFSN	INOX 	v _c m/min f _z mm a _p mm	165-265 0,20-0,30 1,0-6,5	95-155 0,20-0,23 1,0-4,9	190-280 0,2-0,4 0,5-6,0	-	-	-	10 Δ	24,70	...5173

(W282)

Δ Solo es posible la entrega de una unidad de embalaje completa.

Fresa para planear de 45° (sujeción mediante tornillos)

Ø D mm	Z	Ø d H7 mm	Ø d1 mm	L mm	Ø D1 mm	a _p máx. mm	Plaquita de corte	format	
								2999	Ref.
50	4	22	63	50	18	6,5	SEKN/SEER 1203...	548,06	...0300
63	5	22	76	50	18	6,5	SEKN/SEER 1203...	643,34	...0305
80	6	27	93	50	38	6,5	SEKN/SEER 1203...	691,01	...0310

(W280)



format
professional quality

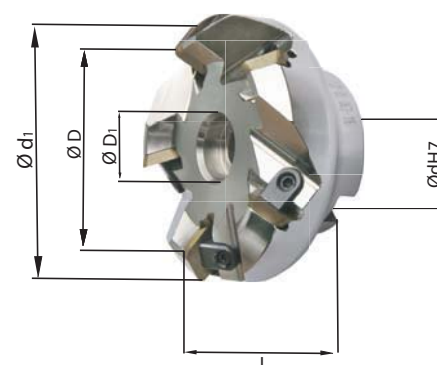

Suministro sin plaquitas de corte.

Pieza de recambio

Características	format		Ref.
	5840	5886	
Llave Allen, 4 mm	0,41	-	...0040
Destornillador T9 x 60 mm	-	10,59	...0035
Destornillador T15 x 80 mm	-	10,90	...0050

(W528) (W543)

Llave Allen

Destornillador