

Fresa de disco con reborde

Ø D mm	Z	Ø d H7 mm	H mm	S mm	Ø d <sub>1</sub> mm	a <sub>p</sub> máx. mm	Plaquita de corte	format	Ref.
								2999	€
63	6	16	10.5	4	34	10.5	SNHQ 1102...	701,28	...1600
63	6	16	10.5	6	34	10.5	SNHQ 1203...	701,28	...1610
80	8	22	17.5	6	40	17.5	SNHQ 1203...	780,23	...1620
100	10	27	23.5	6	48	23.5	SNHQ 1203...	880,71	...1625
160	16	40	41	10	70	41	SNHQ 1205...	1.187,81	...1635

(W101)

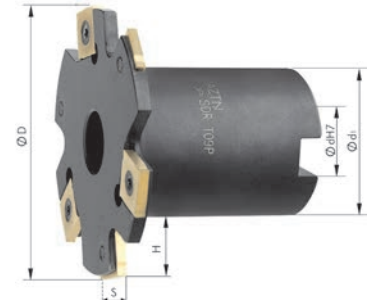

Suministro sin plaquitas de corte.

Pieza de recambio

Características	U.E.	format	format	format	Ref.
		2999	5879	5883	
Tornillo para plaquitas de corte 1102	10 Δ	5,56	-	-	...0100
Tornillo para plaquitas de corte 1103	10 Δ	5,56	-	-	...0105
Tornillo para plaquitas de corte 1203	10 Δ	5,95	-	-	...0110
Tornillo para plaquitas de corte 1204	10 Δ	5,95	-	-	...0115
Tornillo para plaquitas de corte 1205	10 Δ	5,95	-	-	...0120
Tornillo para plaquitas de corte 1207	10 Δ	5,95	-	-	...0125
Destornillador con mango tipo bandera para plaquita 11, T9 x 40	1	-	3,16	-	...0005
Destornillador con mango tipo bandera para plaquita 12, T15 x 45	1	-	3,16	-	...0015
Destornillador para plaquita de corte 11, T9 x 60	1	-	-	4,96	...0035
Destornillador para plaquita de corte 12, T15 x 80	1	-	-	4,98	...0050

Δ Solo es posible la entrega de una unidad de embalaje completa. (W101) (W113) (W113)



Tornillo



Destornillador con mango tipo bandera



Destornillador

Plaquita de corte ISO



Designación ISO	Tipo de material de corte	Velocidad de corte Avance	P	M	K	N	S	H	U.E.	format	Ref.
			acero	inoxidable	fundición	aluminio	superaleac.	templado		2999	
SNHQ 1102AZTN-M	PMK 9130 	v <sub>c</sub> m/min f <sub>z</sub> mm	220-255 0,2-0,4	100-125 0,2-0,35	230-270 0,2-0,5	- -	- -	- -	10 Δ	15,95	...5500
SNHQ 1102AZTN-M	U 9145 	v <sub>c</sub> m/min f <sub>z</sub> mm	165-210 0,2-0,4	75-100 0,2-0,5	100-150 0,2-0,5	- -	30-70 0,1-0,2	- -	10 Δ	15,95	...5503
SNHQ 1103AZTN-M	PMK 9130 	v <sub>c</sub> m/min f <sub>z</sub> mm	220-255 0,2-0,4	230-270 0,2-0,35	230-270 0,2-0,5	- -	- -	- -	10 Δ	15,95	...5506
SNHQ 1203AZTN	PMK 9130 	v <sub>c</sub> m/min f <sub>z</sub> mm	230-270 0,2-0,4	135-160 0,2-0,3	215-255 0,2-0,4	345-945 0,2-0,4	- -	- -	10 Δ	15,85	...5511
SNHQ 1203AZTN-M	U 9145 	v <sub>c</sub> m/min f <sub>z</sub> mm	230-270 0,2-0,4	135-160 0,2-0,3	215-255 0,2-0,4	- -	30-70 0,1-0,2	- -	10 Δ	15,63	...5515
SNHQ 1204AZTN-M	U 9145 	v <sub>c</sub> m/min f <sub>z</sub> mm	225-255 0,2-0,4	135-150 0,2-0,3	210-240 0,2-0,4	- -	30-70 0,1-0,2	- -	10 Δ	17,76	...5521
SNHQ 1205AZTN	PMK 9130 	v <sub>c</sub> m/min f <sub>z</sub> mm	205-255 0,2-0,5	120-150 0,2-0,38	190-240 0,2-0,5	305-890 0,2-0,5	- -	- -	10 Δ	18,81	...5524
SNHQ 1205AZTN-M	U 9145 	v <sub>c</sub> m/min f <sub>z</sub> mm	210-255 0,2-0,5	125-150 0,2-0,38	195-240 0,2-0,5	- -	30-70 0,1-0,2	- -	10 Δ	18,81	...5527
SNHQ 1207AZTN	PMK 9130 	v <sub>c</sub> m/min f <sub>z</sub> mm	195-250 0,2-0,5	115-150 0,2-0,38	185-235 0,2-0,5	- -	- -	- -	10 Δ	19,96	...5530

Δ Solo es posible la entrega de una unidad de embalaje completa. (W101)